

prototypeprojects

POWERED BY  matrix

CNC MACHINING GUIDE TO OUR 3-DAY PRODUCTION SPEED



GUIDE TO OUR CNC 3-DAY PRODUCTION SPEED

Depending on your technical requirements and project timescales, we offer three production speeds: 3, 7, and 12 days, with parts shipped with next day delivery. We never compromise on quality to achieve the rapid turnaround of our 3-day service or the lower cost of the 12-day service.

If you want your CNC machined part dispatched in 3 working days, your part must meet all of the criteria detailed below. If your part does not meet the criteria, you will need to choose one of our other production speeds.

DEPTH OF CUT

Dimension A Cutter Dia Ø	Dimension B Depth of Cut
1mm	5mm
2mm	20mm
3mm	25mm
4mm	40mm
6mm	60mm

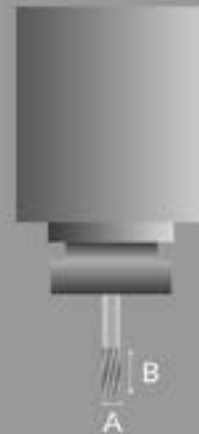

SIZE

Milling

Your part must fit into one of these billet sizes:

- 150mm x 50mm x 40mm
- 100mm x 50mm x 40mm
- 50mm x 50mm x 40mm

Parts can be made from, Aluminium 6082, Acetal (black and natural) and Clear Acrylic.

Turning

- 60mm max dia in Aluminium 6082
- 60mm max dia in Acetal (black and natural)
- 60mm max dia in Clear Acrylic
- 60mm max dia in Stainless Steel (316/304)

MATERIALS

Numerous types of metal and plastic material can be machined using CNC machining. We keep a stock of commonly used materials in-house. Only the materials listed below are available on our 3-day production speed. If you require different materials, you will need to choose one of our other production speeds.

- Acetal – black and natural
- Acrylic – clear
- Aluminium – 6082

SURFACE FINISHES

All machined parts are vapour blasted, as standard. Other finishes are available on request, but will need to be ordered using one of our other production speeds.



TEXT

Here are some considerations, should your part incorporate text:

- 0.5mm is the minimum stroke width for recessed text
- 0.5mm, or greater, spacing should be used between characters on raised text
- Recessed text is better than raised text

THREADED HOLES

Threaded holes of M2 – M12 (model drill hole size) are supported on our 3-day production speed. Standard threads only. For through tapped holes make hole size suit drill \varnothing M1-M12. See the diagram below for details.

Tap size	Hole Size in CAD \varnothing mm
M1.6	1.25
M2	1.6
M3	2.5
M3.5	2.9
M4	3.3
M5	4.2
M6	5
M7	6
M8	6.8
M9	7.8
M10	8.5
M11	9.5
M12	10.2

Example for M3 tapped hole

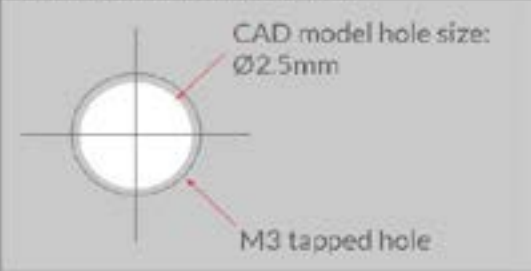

The diagram shows a circular cross-section of a hole. A red arrow points to the outer diameter of the hole, labeled 'CAD model hole size: \varnothing 2.5mm'. Another red arrow points to the inner diameter of the hole, labeled 'M3 tapped hole'.

Drill depth clearance for blind holes:

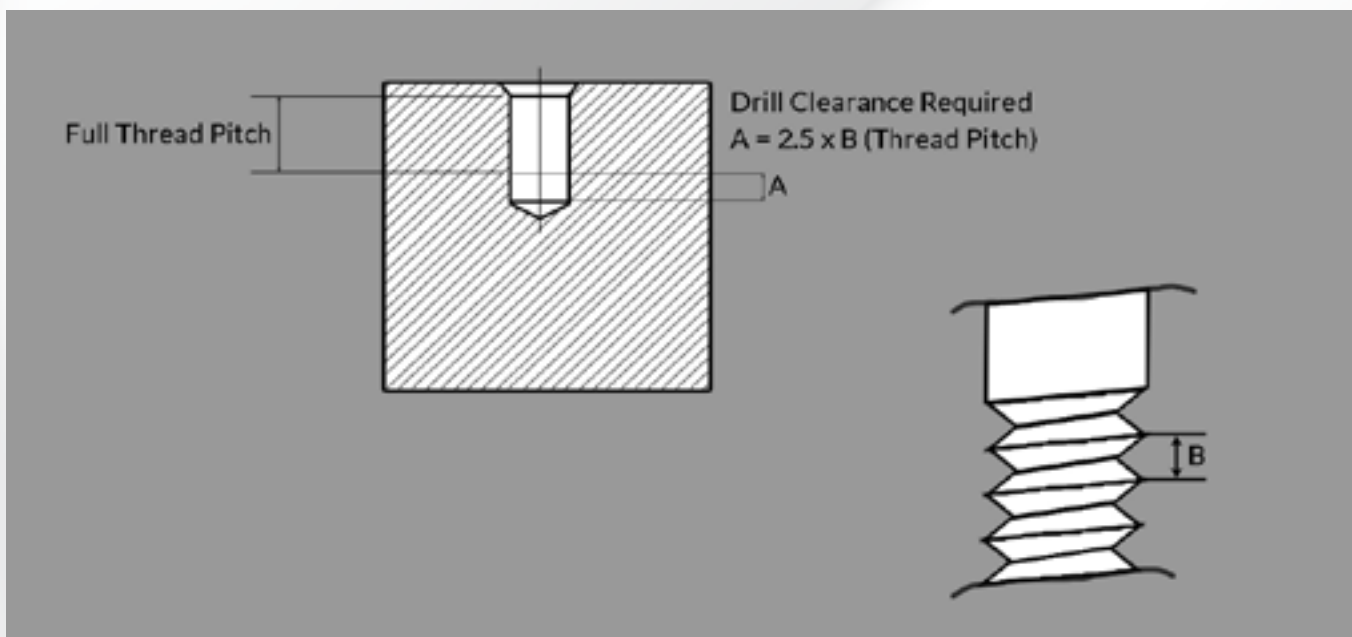

RADII

As a natural result of the CNC machining process, the sharp inside corners of a part will be rounded (radiused). The resulting radii will be identified before the part is milled as this will depend on the depth of the feature.

Sharp corner concession:

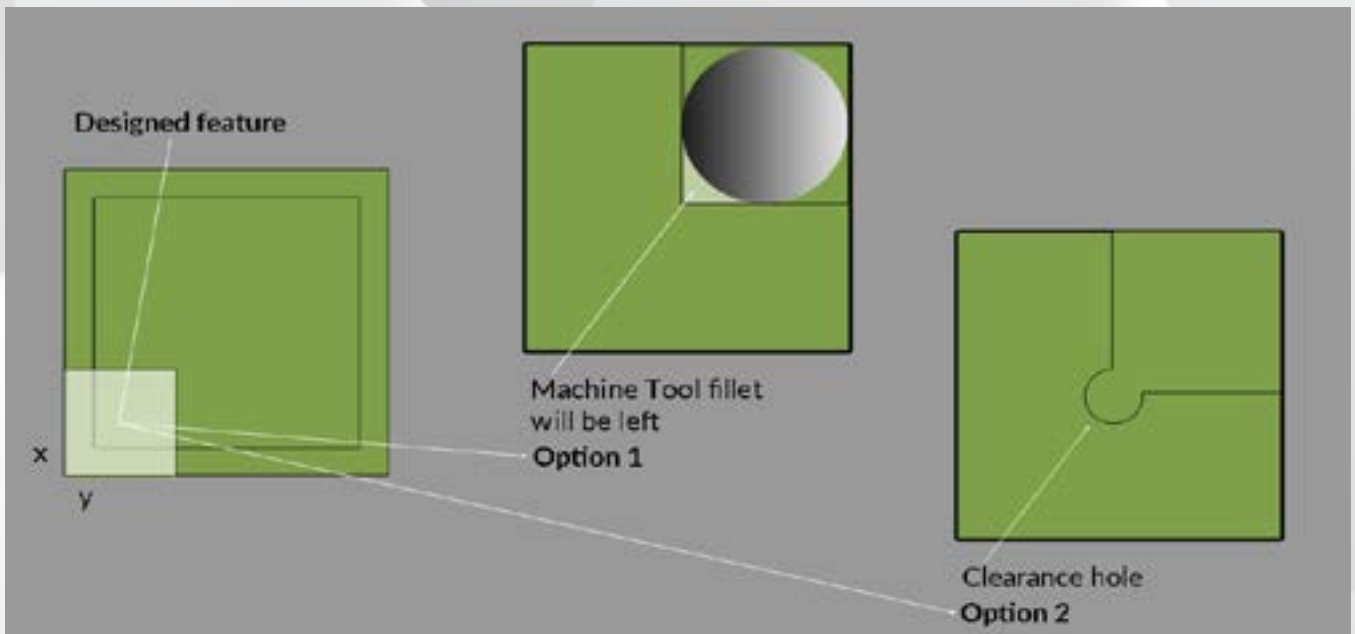

CNC 3-DAY PRODUCTION SPEED NOTES

- General machining tolerance: ± 0.1
- Hole tolerance: H7
- Number of items and quantity of limited (geometry specific)
- Maximum of five separate parts may be included in one quote request
- Inspection: basic visual to CAD

CAN WE HELP YOU?

We are always happy to offer our advise so please do either contact our Business Relations Team to discuss your needs, or contact us to arrange a tour of our facilities.

BUSINESS RELATIONS TEAM

Our Business Relations Team manages everything from customer quotations, to fulfilment, dispatch and invoicing. If you'd like to meet the team, please get in touch.

TAKE THE TOUR

We encourage our customers to visit our prototyping bureau in Royston so we can show you our full range of services and answer any questions about your next project. If you would like to arrange a tour, please contact us.

T: 01763 249760

E: office@prototypeprojects.com

prototypeprojects

POWERED BY  **matrix**

Unit 2 Greenfield, Royston, Hertfordshire SG8 5HN

01763 249760

office@prototypeprojects.com

prototypeprojects.com

